

LIMITED WARRANTY

For one (1) year from the date of purchase, The Guest Co., Inc. will, at its discretion, repair or replace for the original consumer, free of charge, any part or parts found upon examination by Guest Co., Inc., 48 Elm St., Meriden, Connecticut to be defective in material or workmanship or both. Proof of purchase required. All transportation charges under this warranty must be borne by the consumer.

THERE IS NO OTHER EXPRESSED WARRANTY. IMPLIED WARRANTIES, INCLUDING THOSE OF MERCHANTABILITY AND FITNESS FOR A PARTICULAR PURPOSE, ARE LIMITED TO ONE YEAR FROM THE DATE OF PURCHASE. THIS IS THE EXCLUSIVE REMEDY AND CONSEQUENTIAL DAMAGES ARE EXCLUDED WHERE PERMITTED BY LAW.

CUSTOMER SERVICE

If you, our customer, have any questions concerning Guest products, parts or warranties, please contact our Service Department Monday through Friday between 9:00 AM and 4:00 PM Eastern Time.

(203)-238-0550
(203)-634-1696 fax

The Guest Co.
48 Elm St. Meriden, CT 06450 USA

A Valley Forge Company

Write for your free copy of the new GUEST catalog.

I-24020

ShipWrite
Services
Use manuals for marine products

GUEST



MODEL 2815M (formerly 2615AM) 15 AMP, 2 - BANK BATTERY CHARGER

INSTALLATION AND OPERATION
INSTRUCTIONS FOR
MODELS 2815M/115 AND 2815M/230

IMPORTANT!

READ THESE INSTRUCTIONS BEFORE
INSTALLING AND USING THIS PRODUCT.

Keep these instructions for future reference

Description

The Guest 2815M ChargePro is a solid-state "3-stage" battery charger and is lightweight, silent and completely automatic. It can produce a full 15 amps of 12 volt DC charging current while using much less AC current than other chargers. This revolutionary new design can rapidly recharge and individually maintain 2 separate battery banks at one time. If a DC short or overload occurs, the charger will reduce its output voltage to a safe level, then automatically return to normal after the overload is removed. Its water resistant polycarbonate housing and urethane coated circuitry make it ideal for harsh environments. Every Guest 2815M charger is tested under load before shipment to assure superior reliability.

Application

This battery charger is ideal for a wide variety of installations using 12 volt lead-acid or gel-cell batteries. Some of the most popular battery configurations are:

- Two Group 24 batteries
- Two Group 27 batteries
- One Group 4D battery and one Group 24 battery

Installations using more or larger batteries are possible, but it may require a longer time to recharge the batteries in these installations. Longer recharging times can also result if there is equipment on board that requires substantial amounts of DC current while at dockside, such as:

- a DC only refrigerator or ice maker
- a DC only air conditioner or heater
- a large number of 12 volt DC lights in use

Two different versions of the Guest 2815M are available:

- The model 2815M/115 for 115 volt AC input, and
- The model 2815M/230 for 230 volts AC input.

Both versions will function with either 50 Hz or 60 Hz AC inputs.

Specifications

Total output current

maximum: 15 amps at 12 volts DC

"float" mode: 0.1 to 0.3 amps at 13.5 volts DC

Output voltage:

with 15 amp load: 12 volts DC minimum

finish ("float") voltage: 13.5 volts DC (+/- 0.1 volts DC)

Input voltage - 2815M/115: 90 to 140 volts/50 or 60 Hz AC

Input voltage - 2615M/230: 190 to 240 volts/50 or 60 Hz AC

Max. AC draw at 115 volts: 3 amps

Housing dimensions 9"H x 7 7/8"W x 4"D

Diagram 1 Guest 2815M charging method

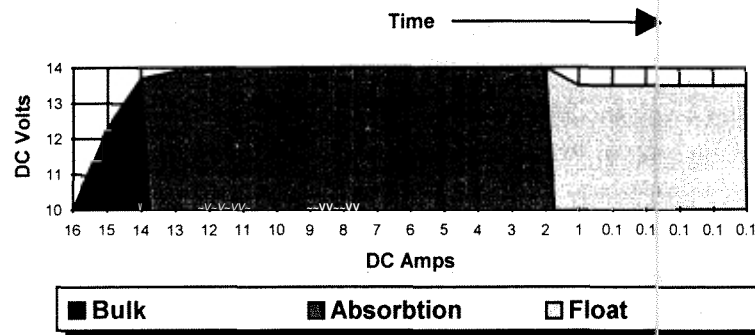

This device meets or exceeds FCC Part 15 Standards relating to RF interference. This device is not intended for use with combination 12/24 volt battery systems.

If your vessel does not already have an ABYC approved AC dockside power system, The Guest Company strongly recommends that you consult with a qualified marine electrician before installing this device. Improper AC connections can cause physical injury or damage to your vessel.

Operation

When the 2815M charger senses a drop in battery voltage, it automatically increases its output to re-charge the battery. By using a sophisticated 3 stage charging method, it recharges your batteries in the fastest, healthiest way.

The amp meter on the front of the charger shows the total combined charging current during the first and second charging stages, ("bulk" charging and "absorption" charging). When the low battery approaches full charge, the charger reduces its output to a "float" charging rate, indicated by the green LED light. This low float voltage gently "tops off" your batteries, then keeps them fully charged and ready for use without overcharging.

The total 15 amp output of this charger is divided between both of the batteries connected to it, however the charge being applied to each battery is individually regulated.

When using the 2815M to charge a single battery, a jumper wire, (not included), *must* be connected between the two DC positive (+) outputs of the charger. (See page 10.)

The Guest ChargePro 2815M battery charger is fully automatic, requires no maintenance, and can be left unattended indefinitely. However, the electrolyte (battery acid) in lead-acid batteries can gradually evaporate, particularly in warm climates. Check your batteries once a month as a part of your maintenance routine.

Overload Protection

If an electrical overload (excessive demand) occurs in the DC system connected to this charger, it will reduce its output voltage to a safe level. In the event of a dead short, the charger's output voltage will effectively be zero volts.

Once the overload or short is removed, the 2815M will automatically resume normal operation.

Checklist for required tools and materials

X	Qty	Tools
		Electric drill with 1/4" and 1/16" drill bits
		Wire cutting and crimping tools
		1/4" slotted screwdriver
	2	5/16" and 3/8" socket wrenches or nut drivers
		Portable DC volt meter
		Safety glasses, work gloves, and long sleeved shirt
		Additional materials
	4	#10 SS hex head or round head machine bolts. (Bolt length = mounting surface thickness plus 1".)
	4	each #10 SS flat washers, lock washers and hex nuts.
	20	7" cable ties w/mounting holes (ex: Beckson L-7MH).
	20	# 8 x 3/4" SS pan head self-tapping screws (for fastening cable ties to mounting surface).
		AC wiring
	1	5 amp AC circuit breaker or fuse (if one is not already installed and available in your Main AC panel).
	6	#8 ring terminals (to attach the AC input wires to the charger and to the main AC panel).
	as req.	3 conductor, 14 gauge Marine UL listed AC cable to bring power from your AC Main panel to the charger.
		DC wiring
	as req.	Tinned, stranded copper wire to connect the charger's DC outputs to your batteries. (<i>Red</i> wire for positive (+) connections and black wire for negative (-) connections). Use the table "DC wire size" on page 8 to determine the correct diameter wire to use for your installation.
	4	#10 ring terminals to attach DC output wires to charger.
	3	5/16" ring terminals (for connecting the DC output wires to the batteries' positive (+) terminal posts).
	1	ring terminal to fit the engine's negative (-) ground post

Installation

CAUTION!

Before beginning this installation -

- Open engine hatches and operate bilge blowers for 10 minutes to remove dangerous fumes and hydrogen gas.
- Disconnect all AC power sources.
- Disconnect negative battery cables from all batteries.
- Wear safety goggles, gloves and long sleeved shirt when drilling or while handling batteries.

Choosing a mounting location

1. Mount this charger in an upright position only, with the aluminum cooling fins running vertically. It is important that the charger have at least 6 inches of unrestricted airflow on all sides for effective cooling. Do not install onto a carpeted, upholstered, or varnished surface.
2. Although this charger is ruggedly designed, avoid mounting it in an area that is open to rain, snow or spray.
3. Avoid mounting this charger within 3 feet of a compass, TV or FM radio.
4. Select a mounting location which will allow the shortest DC wires between the charger and the batteries.
5. Do not mount this unit directly over your batteries because their corrosive fumes can damage the circuitry inside this charger.
6. Be sure that the mounting location will allow access to the connections on the charger after it is mounted.

Preparing the mounting location

1. Hold the battery charger against the surface where you are planning to mount it. (Be sure that you will be able to drill holes through this surface later without damage to wiring, tanks or other equipment.) Using a pencil, mark the locations of the battery charger's four mounting holes onto the mounting surface
2. Drill four 1/4" holes through the mounting surface at the locations you marked with pencil.

Note: Do not mount the charger until after you have made the following electrical connections.

Electrical connections

Installing the Guest 2815M/115 or 2815M/230 requires making two different types of electrical connections: the DC (12 volt battery system) and the AC (dockside power).

Planning the DC connections

You can configure the Guest 2815M charger to maintain one or two separate 12 volt batteries. There are several ways to connect this charger into your present 12 volt system.

The simplest and most widely used connection method is:

1. Run one red DC wire from each of the charger's two DC positive (+) outputs to the positive posts of each battery. When charging a single battery, you *must* connect both charging outputs to the battery.
2. Connect a black DC wire from the charger's common negative (-) terminal to the engine block's common negative ground terminal.

This method is illustrated in diagram 2 on page 7.

Planning the DC connections (cont.)

This is the most common type of battery charger installation:

Diagram 2

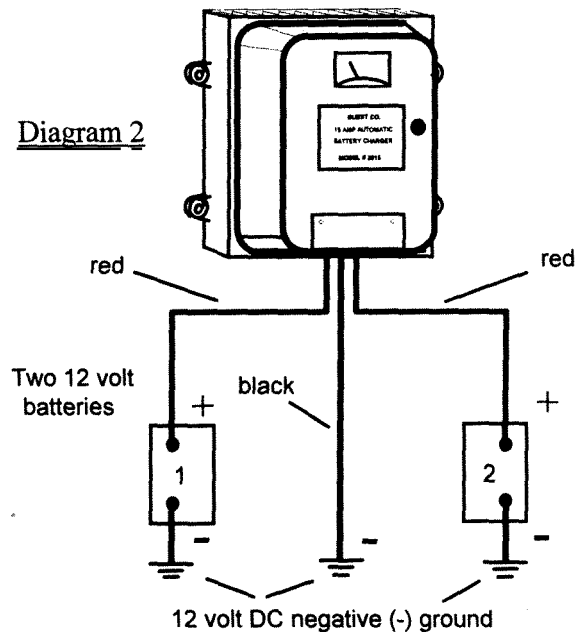

Two alternative methods for making the DC connections are:

1. connecting the DC positive (+) outputs of the charger to the battery connections on your battery switches or
2. connecting the DC positive (+) outputs of the charger to the *output* posts of your battery isolator. (Do NOT connect the charger's outputs to an isolator's inputs.)

These methods are only recommended if your 2815M will be mounted much closer to your battery switches or battery isolator, than it will be to your batteries.

For sample diagrams of these types of installations, refer to Guest document I-21681. This is included with all Guest battery switches and isolators, and is available on request.

Making the DC connections

1. Use the following table to determine the gauge (thickness) of the wire you will need to carry the current from the charger to your batteries safely and efficiently.

Recommended DC wire sizes

Length of wire, (in feet) as measured from the battery charger to the farthest battery and back to the charger (maximum 3% voltage drop)

Max. amps	10 feet	15 feet	20 feet	25 feet	30 feet	40 feet	50 feet
10	14 ga.	12 ga.	10 ga.	10 ga.	10 ga.	8 ga.	6 ga.
15	12 ga.	10 ga.	10 ga.	8 ga.	8 ga.	6 ga.	6 ga.
20	10 ga.	10 ga.	8 ga.	6 ga.	6 ga.	6 ga.	4 ga.
25	10 ga.	8 ga.	6 ga.	6 ga.	6 ga.	4 ga.	4 ga.
30	10 ga.	8 ga.	6 ga.	6 ga.	4 ga.	4 ga.	2 ga.
40	8 ga.	6 ga.	6 ga.	4 ga.	4 ga.	2 ga.	2 ga.
50	6 ga.	6 ga.	4 ga.	4 ga.	2 ga.	2 ga.	1 ga.

from section E9, table VII of the American Boat and Yacht Council (ABYC)
"Standards and Recommended Practices for Small Craft"

2. Find a path for the DC wires between the charger and your batteries. Remember to route the wires away from hot surfaces or other areas where the wires could be damaged. Make sure you will be able to fasten a cable tie to a solid surface at least every 18 inches throughout the length of the wires to support them according to ABYC standard E-9.15h.

The DC connections (continued)

- You will also need to establish a path between the charger's common DC negative output and the common negative (-) engine ground connection. This is normally where the batteries' negative cables connect to the engine block. (When installing this unit in outboard powered boats, the DC negative (-) charger output will be connected directly to the negative (-) terminal of one or both batteries.)

CAUTION!

Do not connect any wires to the batteries or to the charger until AFTER you have cut each one to size, crimped an appropriate connector onto each end and securely mounted the wires with the screw-down cable ties. This can help to prevent accidental short-circuits during your installation.

- After you have determined an appropriate path for the DC wires to each battery, cut them to size, leaving three feet extra. Strip 3/8" of insulation from the battery ends of the *red* wires. Test fit a 5/16" ring terminal onto the threaded positive (+) posts of your batteries. Remove the ring terminal from the battery post and crimp or solder it onto the battery end of the red wire.
- Repeat step 4 for the red positive wire leading to the other battery's positive post.
- Repeat step 4 for the black wire, using a ring terminal that will fit your engine's negative ground terminal.
- Use screw mounted cable ties or wire straps to fasten all the wires between the batteries and the charger onto solid surfaces. Avoid running wires over sharp edges or near areas of extreme heat.

Remove the two screws on the lower face of the charger to expose the wiring terminals. The AC and DC connection terminals are arranged as shown here:

Diagram 3

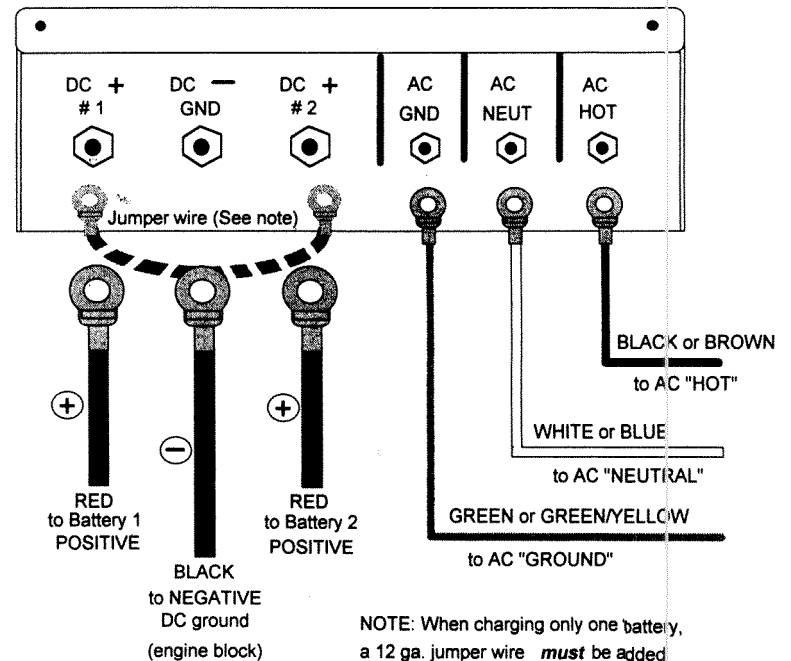

NOTE: When charging only one battery, a 12 ga. jumper wire *must* be added between output posts DC #1 and DC #2.

This is the correct way to attach terminals to the charger:

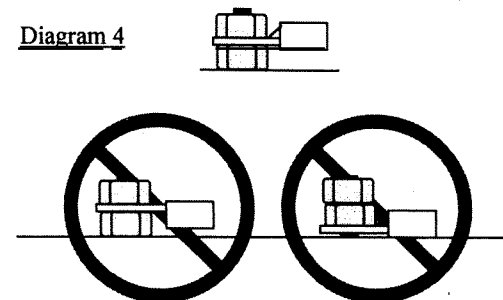

Making the AC connections

CAUTION!

If your vessel does not already have an ABYC approved AC dockside power system, The Guest Company strongly recommends that you consult with a qualified marine electrician before installing this device. Improper AC connections can cause serious physical injury and may damage your vessel.

Before making any AC connections, be **certain** that all sources of AC current have been safely disconnected from the vessel.

DON'T ASSUME !

The Guest 2815M/115 and 2815M/230 chargers each require three AC connections. These connections are:

- a Ground wire (normally green or green/yellow),
- a Neutral wire (normally white or blue) and
- a Hot or Line wire (normally black or brown).

To hard wire the charger into your AC system

1. Determine a safe path for the AC wiring between the charger and Main AC panel. Avoid hot or sharp surfaces.
2. Fasten all wiring onto solid surfaces using screw-mounted cable ties or cable straps every 18 inches.
3. Attach #8 ring terminals onto both ends of the AC wires by crimping or soldering.
3. Install a 5 amp AC circuit breaker or fuse into the AC Hot wire (black or brown), in your Main AC panel. Attach the AC Hot, Ground and Neutral wires from the charger to the appropriate connection points at the Main AC panel.

To use a grounded 3-prong outlet

Do not apply AC power until *after* you have made all of the DC connections. Use AC sockets with a ground fault interrupter (GFCI) breaker. Do not use 2 blade ground adapter plugs.

1. Use only a heavy duty 3 conductor AC cord such as a Guest part # U-2554 or Radio Shack™ part # 278-1258.
2. Crimp #8 ring terminals onto the three AC wires.
3. Make the AC connections on the front of the charger according to diagram 3 on page 10.
4. **Do not plug the charger's cord into an AC outlet until after you complete the following steps.**

Finishing the wiring connections

1. Connect the DC output wires to the DC output terminals of the charger as shown in diagram 3 on page 10. Use a 3/8" socket wrench or nut driver. **Do not over tighten.**
2. Connect the other end of the black (negative) DC wire to the engine's common negative ground, or to the negative posts of both batteries.
3. Connect the other ends of the red (positive) DC wires to the positive posts of your batteries. NOTE: A small spark may occur. This is normal.
4. Confirm that all sources of AC power are turned off. Connect the AC input wires from the AC Main panel to the AC terminals on the charger as shown on diagram 3 on page 10. Use a 5/16" socket wrench or nut driver. **Do not over tighten.**
5. Replace the rectangular cover plate over the screw terminals on the front of the charger, passing each wire through one of the notches in the cover plate. Attach the cover plate to the charger with the screws provided.

You are now ready to fasten the charger onto mounting surface.

Mounting the Battery Charger

Fasten the charger onto the mounting surface as shown here:

Diagram 5

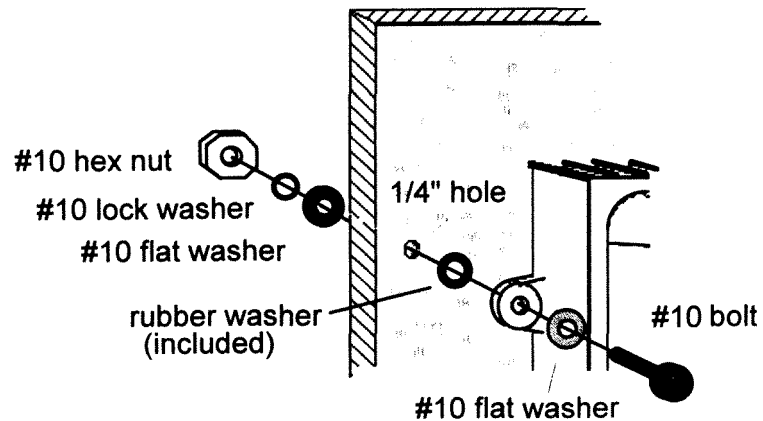

Fasten all wires leading from the charger onto the mounting surface using cable ties. Avoid any sharp edges that might cut the insulation of the wires. This completes your installation.

Testing your installation

Activate the battery charger by re-connecting your dockside AC power. Observe the amp meter on the front of the charger. It should show that current is flowing into your batteries. (Turn on several DC lights if you are not sure if the meter is registering.) When the batteries have reached full charge, the green LED light on the front of the charger will turn on.

After 24 hours, use a voltmeter to check the voltage at the positive and negative posts of each battery with the charger on. Each battery should read between 13.2 to 13.6 volts DC. If you have large batteries, or a continuous DC load is present, measure the battery voltages after 48 hours.

Problem	Cause	Solution
<ol style="list-style-type: none"> Charger does not seem to be charging batteries. <p>(Note: Measure the voltages in your batteries as described under "Operation" to confirm that there is actually a charging problem.)</p>	<ol style="list-style-type: none"> One or more defective or damaged batteries. Charger has reduced its output voltage below charging level due to a DC overload or a DC short. 	<ol style="list-style-type: none"> Test batteries and replace if necessary. Remove the source of the overload or short, and then re-test the charger as described under "Operation" to confirm that it is charging properly.
<ol style="list-style-type: none"> The green LED light blinks and the amp meter pointer fluctuates rapidly. 	<ol style="list-style-type: none"> Blown DC output fuses due to the charger being attached to the batteries backwards. A single battery has been connected to the charger without tying its two (+) positive outputs together with a jumper wire (Pg. 10) 	<ol style="list-style-type: none"> To replace fuses: <ol style="list-style-type: none"> Unplug AC power. Remove charger cover. Inspect both fuses. If a fuse has blown, use ONLY a Buss ATO 20 amp as a replacement.
<ol style="list-style-type: none"> The green LED never turns on. 	<ol style="list-style-type: none"> A dead short or overload. One or more bad batteries. A heavy DC load on batteries while charging. (such as lights, pumps, etc.) 	<ol style="list-style-type: none"> Disconnect the negative (-) DC output wire from the charger. Re-apply AC power. The green LED <i>only</i> should now light. If it does, the charger is OK. If not, contact The Guest Co.
<ol style="list-style-type: none"> The amp meter does not move and the green LED does not light. 	<ol style="list-style-type: none"> Confirm that AC power is available. Inspect the charger's AC input wiring and wire terminals for damage or loose connections. Component failure. 	<ol style="list-style-type: none"> Connect AC power supply or reset breaker. Disconnect all AC power sources, and then repair wiring. Return charger to Guest Service department.
<ol style="list-style-type: none"> The GFCI breaker, (Ground Fault Circuit Interrupter), turns off whenever the charger is turned on. 	<ol style="list-style-type: none"> There is a problem in the charger's AC connections or the AC power supply. Certain brands of GFCI breakers are unusually sensitive to "switching" 	<ol style="list-style-type: none"> Confirm that the charger's AC cord is intact, then test the AC power supply. Contact Guest service for information.